

To print at home, use heavy weight paper, or card stock. Cut out the cards along the dotted lines. If you're unable to print on both sides, you can simply fold on the center line to make a 2-sided card.

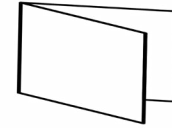

If you use a professional printer, we suggest you print 2-sided cards with white text on red card stock with rounded corners.

Ufite Uburenganzira Bwitegeko nshinga.

- NTUKINGURE URUGI Niba Umuyobozi ushinzwe abanjira n'abasohoka Akomanga kurugi.
- NTUGASUBIZE IKIBAZO ICYARICYO CYOSE cyibajijwe numukozi ushizwe abinjira nabasohoka, nibagerageza kuvugana nawe, ufite uburenganzira bwo guceceka.
- NTUGIRE ICYO USINYA utabanje kuvugana numunyamategeko. Ufite uburenganzira bwo kuvugana numunyamategeko.
- Niba uri hanze yurugo rwawe, baza uwo mukozi niba ufite umudenderezo wo kugenda kandi niba bakubwiye yego, genda utuje.
- TANGA IYI KARITA KUBAYOBOZI Niba uri imbere murugo rwawe, erekana iyi karita ukoresheje idirishya cyangwa uyinyuze muni yumuryango.

I do not wish to speak with you, answer your questions, or sign or hand you any documents based on my 5th Amendment rights under the United States Constitution.

I do not give you permission to enter my home based on my 4th Amendment rights under the United States Constitution unless you have a warrant to enter, signed by a judge or magistrate with my name on it that you slide under the door.

I do not give you permission to search any of my belongings based on my 4th Amendment rights.

I choose to exercise my constitutional rights.

These cards are available to citizens and noncitizens alike.

Ufite Uburenganzira Bwitegeko nshinga.

- NTUKINGURE URUGI Niba Umuyobozi ushinzwe abanjira n'abasohoka Akomanga kurugi.
- NTUGASUBIZE IKIBAZO ICYARICYO CYOSE cyibajijwe numukozi ushizwe abinjira nabasohoka, nibagerageza kuvugana nawe, ufite uburenganzira bwo guceceka.
- NTUGIRE ICYO USINYA utabanje kuvugana numunyamategeko. Ufite uburenganzira bwo kuvugana numunyamategeko.
- Niba uri hanze yurugo rwawe, baza uwo mukozi niba ufite umudenderezo wo kugenda kandi niba bakubwiye yego, genda utuje.
- TANGA IYI KARITA KUBAYOBOZI Niba uri imbere murugo rwawe, erekana iyi karita ukoresheje idirishya cyangwa uyinyuze muni yumuryango.

I do not wish to speak with you, answer your questions, or sign or hand you any documents based on my 5th Amendment rights under the United States Constitution.

I do not give you permission to enter my home based on my 4th Amendment rights under the United States Constitution unless you have a warrant to enter, signed by a judge or magistrate with my name on it that you slide under the door.

I do not give you permission to search any of my belongings based on my 4th Amendment rights.

I choose to exercise my constitutional rights.

These cards are available to citizens and noncitizens alike.

Ufite Uburenganzira Bwitegeko nshinga.

- NTUKINGURE URUGI Niba Umuyobozi ushinzwe abanjira n'abasohoka Akomanga kurugi.
- NTUGASUBIZE IKIBAZO ICYARICYO CYOSE cyibajijwe numukozi ushizwe abinjira nabasohoka, nibagerageza kuvugana nawe, ufite uburenganzira bwo guceceka.
- NTUGIRE ICYO USINYA utabanje kuvugana numunyamategeko. Ufite uburenganzira bwo kuvugana numunyamategeko.
- Niba uri hanze yurugo rwawe, baza uwo mukozi niba ufite umudenderezo wo kugenda kandi niba bakubwiye yego, genda utuje.
- TANGA IYI KARITA KUBAYOBOZI Niba uri imbere murugo rwawe, erekana iyi karita ukoresheje idirishya cyangwa uyinyuze muni yumuryango.

I do not wish to speak with you, answer your questions, or sign or hand you any documents based on my 5th Amendment rights under the United States Constitution.

I do not give you permission to enter my home based on my 4th Amendment rights under the United States Constitution unless you have a warrant to enter, signed by a judge or magistrate with my name on it that you slide under the door.

I do not give you permission to search any of my belongings based on my 4th Amendment rights.

I choose to exercise my constitutional rights.

These cards are available to citizens and noncitizens alike.

Ufite Uburenganzira Bwitegeko nshinga.

- NTUKINGURE URUGI Niba Umuyobozi ushinzwe abanjira n'abasohoka Akomanga kurugi.
- NTUGASUBIZE IKIBAZO ICYARICYO CYOSE cyibajijwe numukozi ushizwe abinjira nabasohoka, nibagerageza kuvugana nawe, ufite uburenganzira bwo guceceka.
- NTUGIRE ICYO USINYA utabanje kuvugana numunyamategeko. Ufite uburenganzira bwo kuvugana numunyamategeko.
- Niba uri hanze yurugo rwawe, baza uwo mukozi niba ufite umudenderezo wo kugenda kandi niba bakubwiye yego, genda utuje.
- TANGA IYI KARITA KUBAYOBOZI Niba uri imbere murugo rwawe, erekana iyi karita ukoresheje idirishya cyangwa uyinyuze muni yumuryango.

I do not wish to speak with you, answer your questions, or sign or hand you any documents based on my 5th Amendment rights under the United States Constitution.

I do not give you permission to enter my home based on my 4th Amendment rights under the United States Constitution unless you have a warrant to enter, signed by a judge or magistrate with my name on it that you slide under the door.

I do not give you permission to search any of my belongings based on my 4th Amendment rights.

I choose to exercise my constitutional rights.

These cards are available to citizens and noncitizens alike.

To print at home, use heavy weight paper, or card stock. Cut out the cards along the dotted lines. If you're unable to print on both sides, you can simply fold on the center line to make a 2-sided card.

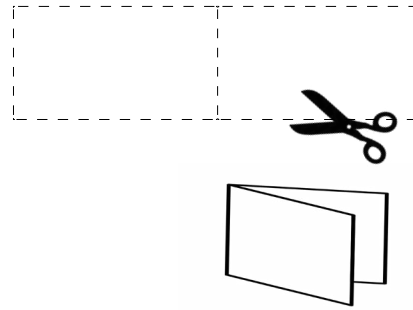

If you use a professional printer, we suggest you print 2-sided cards with white text on red card stock with rounded corners.

Ufite Uburenganzira Bwitegeko nshinga.

- NTUKINGURE URUGI Niba Umuyobozi ushinzwe abanjira n'abasohoka Akomanga kurugi.
- NTUGASUBIZE IKIBAZO ICYARICYO CYOSE cyibajijwe numukozi ushizwe abinjira nabasohoka, nibagerageza kuvugana nawe, ufite uburenganzira bwo guceceka.
- NTUGIRE ICYO USINYA utabanje kuvugana numunyamategeko. Ufite uburenganzira bwo kuvugana numunyamategeko.
- Niba uri hanze yurugo rwawe, baza uwo mukozi niba ufite umudenderezo wo kugenda kandi niba bakubwiye yego, genda utuje.
- TANGA IYI KARITA KUBAYOBOZI Niba uri imbere murugo rwawe, erekana iyi karita ukoresheje idirishya cyangwa uyinyuze muni yumuryango.

I do not wish to speak with you, answer your questions, or sign or hand you any documents based on my 5th Amendment rights under the United States Constitution.

I do not give you permission to enter my home based on my 4th Amendment rights under the United States Constitution unless you have a warrant to enter, signed by a judge or magistrate with my name on it that you slide under the door.

I do not give you permission to search any of my belongings based on my 4th Amendment rights.

I choose to exercise my constitutional rights.

These cards are available to citizens and noncitizens alike.

Ufite Uburenganzira Bwitegeko nshinga.

- NTUKINGURE URUGI Niba Umuyobozi ushinzwe abanjira n'abasohoka Akomanga kurugi.
- NTUGASUBIZE IKIBAZO ICYARICYO CYOSE cyibajijwe numukozi ushizwe abinjira nabasohoka, nibagerageza kuvugana nawe, ufite uburenganzira bwo guceceka.
- NTUGIRE ICYO USINYA utabanje kuvugana numunyamategeko. Ufite uburenganzira bwo kuvugana numunyamategeko.
- Niba uri hanze yurugo rwawe, baza uwo mukozi niba ufite umudenderezo wo kugenda kandi niba bakubwiye yego, genda utuje.
- TANGA IYI KARITA KUBAYOBOZI Niba uri imbere murugo rwawe, erekana iyi karita ukoresheje idirishya cyangwa uyinyuze muni yumuryango.

I do not wish to speak with you, answer your questions, or sign or hand you any documents based on my 5th Amendment rights under the United States Constitution.

I do not give you permission to enter my home based on my 4th Amendment rights under the United States Constitution unless you have a warrant to enter, signed by a judge or magistrate with my name on it that you slide under the door.

I do not give you permission to search any of my belongings based on my 4th Amendment rights.

I choose to exercise my constitutional rights.

These cards are available to citizens and noncitizens alike.

Ufite Uburenganzira Bwitegeko nshinga.

- NTUKINGURE URUGI Niba Umuyobozi ushinzwe abanjira n'abasohoka Akomanga kurugi.
- NTUGASUBIZE IKIBAZO ICYARICYO CYOSE cyibajijwe numukozi ushizwe abinjira nabasohoka, nibagerageza kuvugana nawe, ufite uburenganzira bwo guceceka.
- NTUGIRE ICYO USINYA utabanje kuvugana numunyamategeko. Ufite uburenganzira bwo kuvugana numunyamategeko.
- Niba uri hanze yurugo rwawe, baza uwo mukozi niba ufite umudenderezo wo kugenda kandi niba bakubwiye yego, genda utuje.
- TANGA IYI KARITA KUBAYOBOZI Niba uri imbere murugo rwawe, erekana iyi karita ukoresheje idirishya cyangwa uyinyuze muni yumuryango.

I do not wish to speak with you, answer your questions, or sign or hand you any documents based on my 5th Amendment rights under the United States Constitution.

I do not give you permission to enter my home based on my 4th Amendment rights under the United States Constitution unless you have a warrant to enter, signed by a judge or magistrate with my name on it that you slide under the door.

I do not give you permission to search any of my belongings based on my 4th Amendment rights.

I choose to exercise my constitutional rights.

These cards are available to citizens and noncitizens alike.

Ufite Uburenganzira Bwitegeko nshinga.

- NTUKINGURE URUGI Niba Umuyobozi ushinzwe abanjira n'abasohoka Akomanga kurugi.
- NTUGASUBIZE IKIBAZO ICYARICYO CYOSE cyibajijwe numukozi ushizwe abinjira nabasohoka, nibagerageza kuvugana nawe, ufite uburenganzira bwo guceceka.
- NTUGIRE ICYO USINYA utabanje kuvugana numunyamategeko. Ufite uburenganzira bwo kuvugana numunyamategeko.
- Niba uri hanze yurugo rwawe, baza uwo mukozi niba ufite umudenderezo wo kugenda kandi niba bakubwiye yego, genda utuje.
- TANGA IYI KARITA KUBAYOBOZI Niba uri imbere murugo rwawe, erekana iyi karita ukoresheje idirishya cyangwa uyinyuze muni yumuryango.

I do not wish to speak with you, answer your questions, or sign or hand you any documents based on my 5th Amendment rights under the United States Constitution.

I do not give you permission to enter my home based on my 4th Amendment rights under the United States Constitution unless you have a warrant to enter, signed by a judge or magistrate with my name on it that you slide under the door.

I do not give you permission to search any of my belongings based on my 4th Amendment rights.

I choose to exercise my constitutional rights.

These cards are available to citizens and noncitizens alike.